

MR-15 Overview:

The MR Series is a robust vibratory bowl finishing machine built to handle continuous duty operation. Hammond Roto-Finish's proven welded-construction design was reimagined in 2011 to simplify manufacturing without sacrificing durability. The MR Series combines that innovative design with high-end features.

The MR-15 is available in four models; Manual, Semi-Auto, Automatic, and Accelerated Chemistry. General machine data and features are laid out below.



Machine Features:

Max operating capacity 15.0ft³ (424 L)

Heavy-duty 3/16" (4.75mm) welded construction

- Main bowl construction component is a pressure vessel tank head
- U shaped process channel with textured, straight wall polyurethane lining
- Polyurethane lining is a minimum 5/8" (15.5mm) thick, with 50% additional in high wear areas
- Bowl is suspended on heavy duty coil springs
- Two (2) sets of pop-in drains: solid, 1/16" (1.5mm), **1/8" (3mm)** & 1/4" (6.5mm) slots
- Parts separation system with pneumatically operated gate
- One (1) set of urethane-coated separation screens: **3/4" (20mm)** & 1 1/4" (32mm) openings
- Water-driven compound system – mixes between 0% and 5% concentration
- 19 mm socket included for changing eccentric weights
- Integrated lifting eyes
- Grease lubrication
- Available voltages: 230 VAC / 460VAC, 3ph, 60hz
(denotes factory installed – unless specified on order)

MR-15 Specifications and Dimensions:

Drawings:

MR-15M, MR-15S, MR-15A, MR-15C

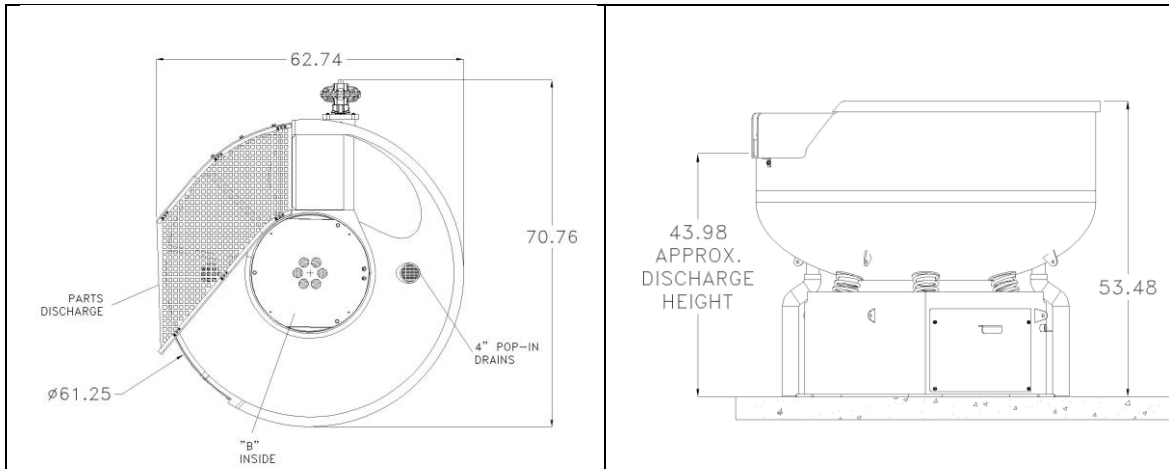

Utilities:

	Bowl Working Volume	Power	FLA (230V/460V)	Shipping Weight	Maximum Water Pressure	Average Flow Rate	Maximum Flow Rate	Drain
English	15.0 ft ³	7.5 hp	20.4 / 10.2	1730 lbs	35 psi	22 gal/hr	4 to 40 gal/hr	(2)
Metric	425 L	5.59 kW		785 kg	2.4 bar	83 L/hr	15 to 151 L/hr	2" NPT

<input type="checkbox"/> Manual Model: MR-15M	POR
--	-----

This is the baseline machine model. It features manual controls for both motor start and the pneumatically operated gate.

<input type="checkbox"/> Semi-Auto Model: MR-15S	POR
---	-----

This is the baseline machine model. It features the shut off timer and pneumatically operated gate on the control panel. It can be upgraded to include a VFD.

VFD Upgrade Price	POR
-------------------	-----

<input type="checkbox"/> Automatic Model: MR-15A	POR
---	-----

This model delivers automation to the MR-15. In addition to the pneumatic gate, it features a PLC with HMI, VFD, and a swinging top eccentric weight. These features work together to automatically process and unload parts from a single Cycle Start button push.

<input type="checkbox"/> Accelerated Chemistry Model: MR-15C	POR
---	-----

This model builds on the MR-15A. In addition to the automatic processing and unloading, it features a second, electric compound pump, part recipe selection from the HMI, and acid proof construction. These features are required in a machine that produces the high luster finishes generated from accelerated chemistry processes.



Common MR-15 Options:	USD	
	MR-15S/A/C	MR-15FB
<input type="checkbox"/> Special Voltage <input type="checkbox"/> 208VAC / <input type="checkbox"/> 575VAC	POR	
<input type="checkbox"/> Automatic Grease Lubricator	POR	
<input type="checkbox"/> End of Cycle Light ²	POR	
<input type="checkbox"/> RYG Stack Light (A and C models only) ²	POR	N/A
<input type="checkbox"/> PVC Coated Wire Mesh Screen (specify size)	POR	N/A
<input type="checkbox"/> Specialty Screen	POR	N/A
<input type="checkbox"/> Media Diverter	POR	N/A
<input type="checkbox"/> Specialty Drain	POR	
<input type="checkbox"/> Pneumatic Closable Drain	POR	
<input type="checkbox"/> Specialty Urethane Lining	POR	
<input type="checkbox"/> Outer curve wall "kicker"	POR	
<input type="checkbox"/> Unload Plug 4" Opening	POR	
<input type="checkbox"/> Media Classification: includes urethane-coated screen with 1/4" openings	POR	N/A
<input type="checkbox"/> Presentation Deck: For use with magnetic separation	POR	N/A
<input type="checkbox"/> Specialty Media Classification Screen ¹	POR	N/A
<input type="checkbox"/> Screen-deck mounted Rinse Bar ²	POR	N/A
<input type="checkbox"/> Screen-deck mounted Air Knife ²	POR	N/A
Settling Tank: 30 gal (110 L) cap. with center baffle ³		
<input type="checkbox"/> Painted Steel	POR	
<input type="checkbox"/> Stainless Steel	POR	
Lift Station: 30 gal (110 L) cap. with center baffle, pumps 100ft (30m) horizontally ⁴		
<input type="checkbox"/> Painted Steel	POR	
<input type="checkbox"/> Stainless Steel	POR	
<input type="checkbox"/> Bolt-On Flexible Fabric Noise Cover ⁵	POR	
<input type="checkbox"/> Hanging Flexible Fabric Noise Cover ⁵	POR	
<input type="checkbox"/> Base Riser 2" to 24" (2" increments) Higher POR	POR	
<input type="checkbox"/> Special Paint	POR	
<input type="checkbox"/> Factory Run Off	POR	

¹ = Depends on the option above	² = Pick only one from the set
Select either only Item ³ or Item ⁴	⁵ = Pick only one from the set